



**Numero di inventario: 19561**

### Centro di lavoro universale DMG DMU 60 P hy-din



### Dati tecnici

Tavola circolare: diametro	630 mm
Numero di assi totale	5 Simultan
Corsa longitudinale (X-asse)	600 mm
Corsa trasversale (Y-assi)	700 mm
Corsa verticale (Z-Asse)	600 mm
Lunghezza massimo della pale	mm
Invertitore di utensili:	
numero utensili	180
Attacco cono mandrino:	BT 40
Velocità mandrino:	
con variatore continuo	
fino	18000 g/min
Dimensioni macchina:	total
Lunghezza	7500 mm
Larghezza	4500 mm
Accessori diversi:	
Gioco di portautensili	BT 40 ca 150x
Pompa refrigerante alta pressione	40 bar
Lubrificazione passare mandrino	

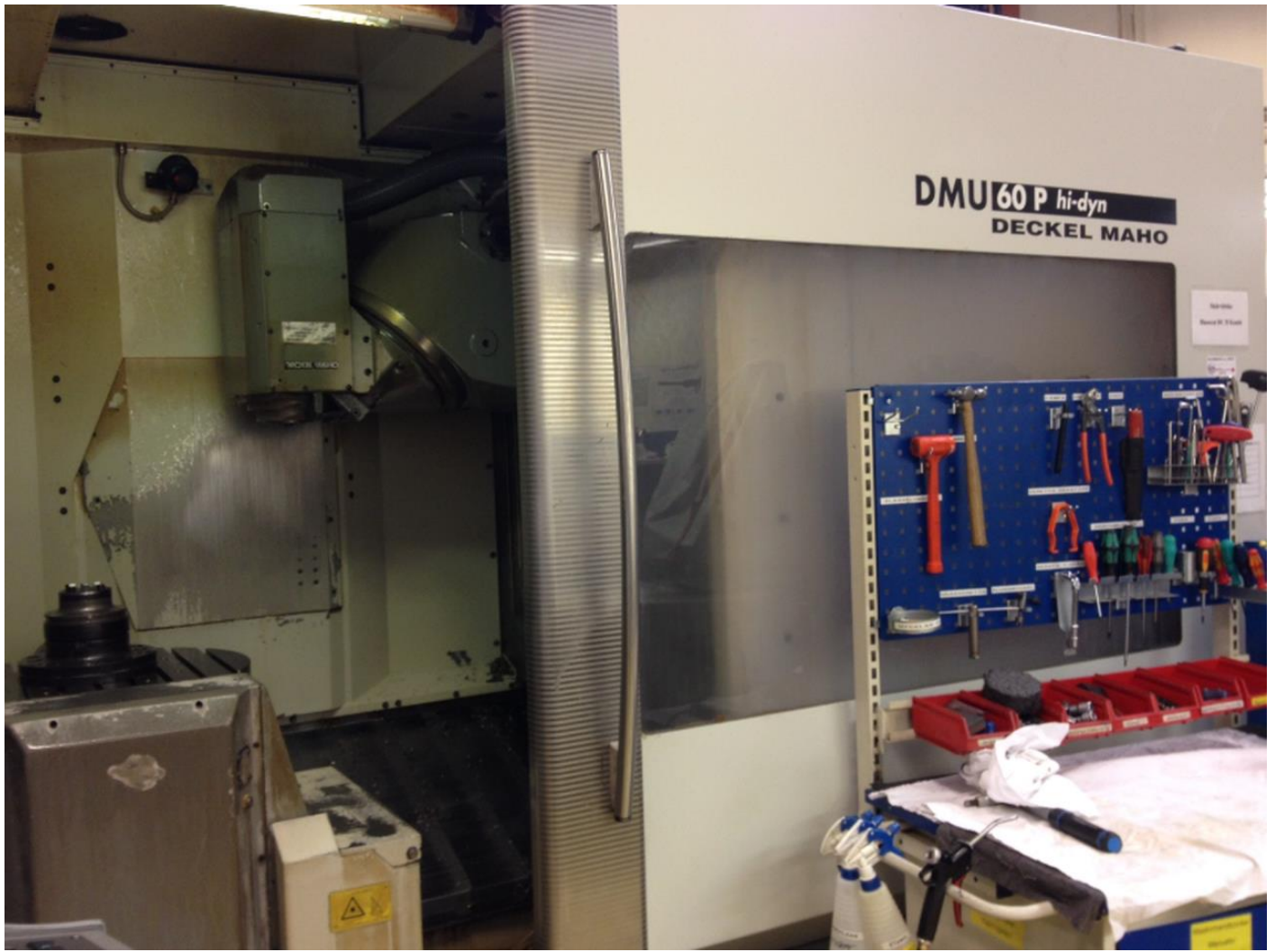





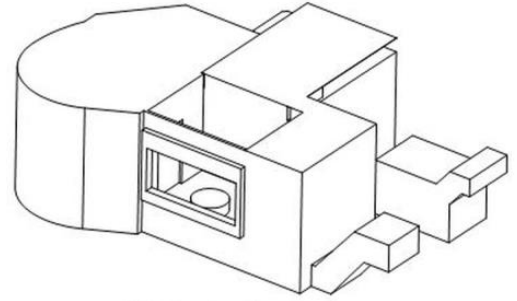
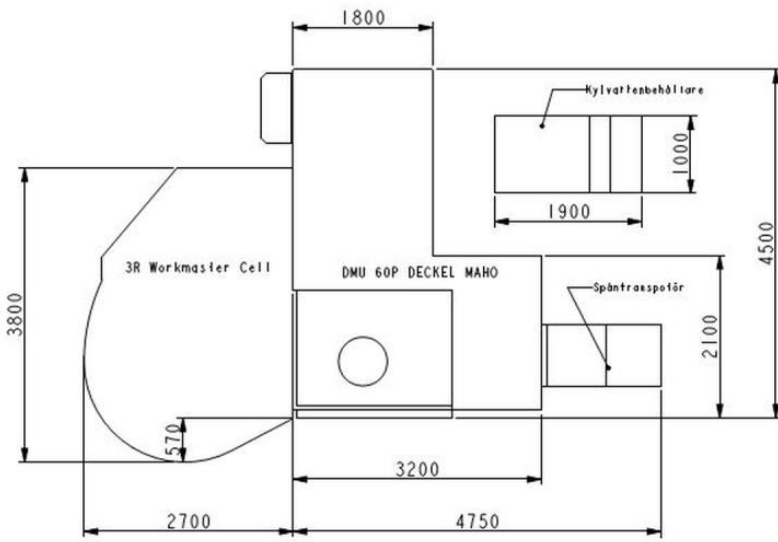
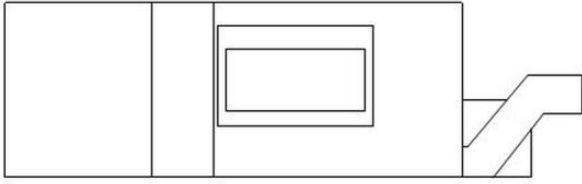

SCALE 2:125



